ENERGY ANALYSIS AUTOMATION FOR INDUSTRIALIZED CONSTRUCTION PROCESSES

Tamás Rácz, PhD candidate, tamas.racz@ltu.se
Anders Rönneblad, Lic. Tech, anders.ronneblad@ltu.se
Thomas Olofsson, Professor, thomas.olofsson@ltu.se
Luleå University of Technology, Luleå, Sweden

ABSTRACT

Industrialized concept buildings such as Skanska's ModernaHus need advanced computer systems to support product configuration processes efficiently. The project phases composed of capturing requirements, design document creation, performance analysis, scheduling and all other activities need to be performed automatically at least to a certain extent in order to maximize benefits for the industrialized building process. This paper demonstrates the development of an automated building energy analysis software module which is going to be part of an experimental configuration system, based on the Skanska's ModernaHus concept buildings. The paper shows the process of software module development from specification, through the selection of system architecture and implementation to first results. The selected approach provides adequate level of flexibility to support re-use in a more complete experimental configuration system in the future. We conclude the paper with discussion on the software development, operation and integration of the module as well as on the first results of efficiency and on the possible further usage for design optimizations. We also show how future organizational and design team roles may shift from classic design tasks towards concept development tasks of product configuration systems when the goal is the implementation of industrialized construction processes.

Keywords: Industrialized Construction, Automation, Energy Analysis, Configuration System

1. INTRODUCTION

Industrialized processes in the construction industry were introduced in the 1960s when the large governmental multi-dwelling program was launched in Sweden. The primary goal was to streamline production with only few possibilities for customization (Kadefors 1995). The most important experience from those days is that the implementation of industrialized processes in the construction industry need to include better support for handling of client requirements. As in other western countries (Egan 1998; Teichholz, Goodrum and Haas 2001), the construction industry in Sweden has been accused for low productivity and quality short-comings (SOU 2002:115; SOU 2009:6). One reply from the Swedish construction industry is to offer customized concept-built multi-dwellings to make the construction process more efficient (Andersson, Apleberger and Molnár 2009). These products require an industrialized building process based on a well developed concept (Winch 2003). The concept owner is responsible for the process as well as the final product, and new projects are based on knowledge and experience from previously completed concept-based building projects.

Developing a new concept involves the development of both a *technical platform* and a *process* (Lessing 2006). The project *delivery phase*, i.e. the individual building project, is also separated from the *concept development phase*. The requirements – defined by the user, property owner, property developer, public programs, local and national regulations – and the constraints imposed by the technical platform must be managed and transformed into a customized building that will satisfy the client. The efficient handling of these vast amount of aspects is only possible with computerized tools therefore the use of ICT is a key requirement both in the concept development phase and in the delivery phase.

Almost the entire manufacturing industry today is struggling with the growing number of product variants in their portfolio. At the same time, there is an increasing pressure to quickly deliver the customized make-to-order products at competitive prices (Patni 2010). Configuration systems have turned out to be one of the most efficient means for creating custom-adopted products (Hvam, Mortensen and Riis 2008). A configuration system stores information in a database of the modularized components and rules how these components can be combined into product variants, also called configurations. Furthermore, it is often desirable to obtain building performance results for a selected configuration to see if the requirements are met. This can be done by connecting the configuring system to different kind of analysis and simulation software. When the requirements are weighed together to obtain an optimally configured end product that meets the requirements of the various stakeholders, a more holistic and integrated design has been reached.

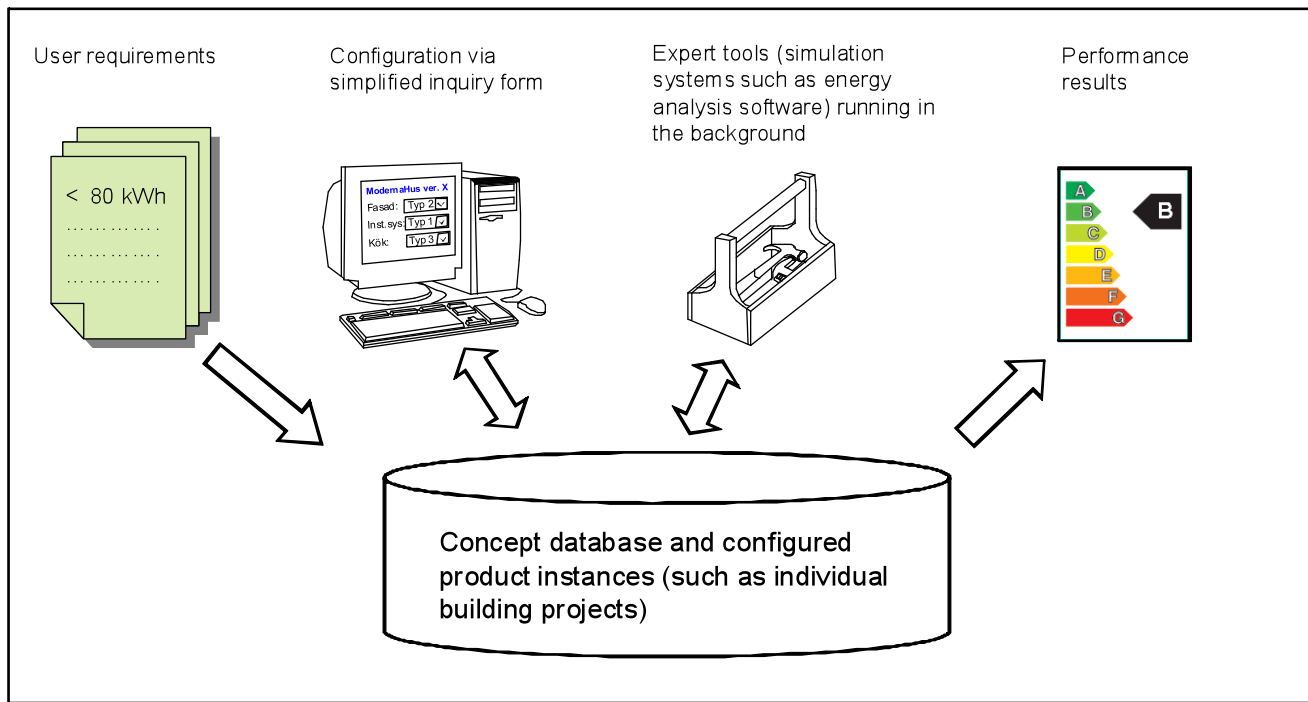

Figure 1: Principal outline of configuration system modules

Our research project’s aim is to develop a general method for handling of different user requirements in industrialized building projects. One part is to create an experimental configuration system, where the selected test area is the life cycle analysis of energy consumptions. The project is based on Skanska’s ModernaHus, see Figure 2, which serves as an example of concept buildings in the research project. The commercialization of Skanska’s ModernaHus has now reached a more mature stage where there is a general awareness of and openness in the company to develop a more general framework of handling user requirements in concept building projects. Skanska’s ModernaHus is one of only a small number of concepts that have been publicly reported in a previous EraBuild project (Häkkinen et al. 2007).

This paper focuses on the software development aspects of a module that should automatically generate energy performance values in an experimental configuration system for the ModernaHus concept. Our intention is to collect experiences on the software development tasks of a concept development process of configuration system modules. Kunz and Fischer (2009) describes the implementation of Virtual Design and Construction in three levels of maturity: 1) Visualization and metrics, 2) Integration and 3) Automation. The third level, the use of automated methods to perform routine design, can significantly reduce design effort and time-to-market. Automation could not only make processes more efficient but also deliver better quality products too. Two sources of the quality improvements are: 1) as a benefit of decreased operation time users of automated solutions

might be able to analyze more options under a given period of time and hence have better opportunities to find the best possible; 2) manual operation carries the potential of introducing errors and omissions in analysis preparation (Bazjanac 2009), the elimination of manual operation remove this possibility.

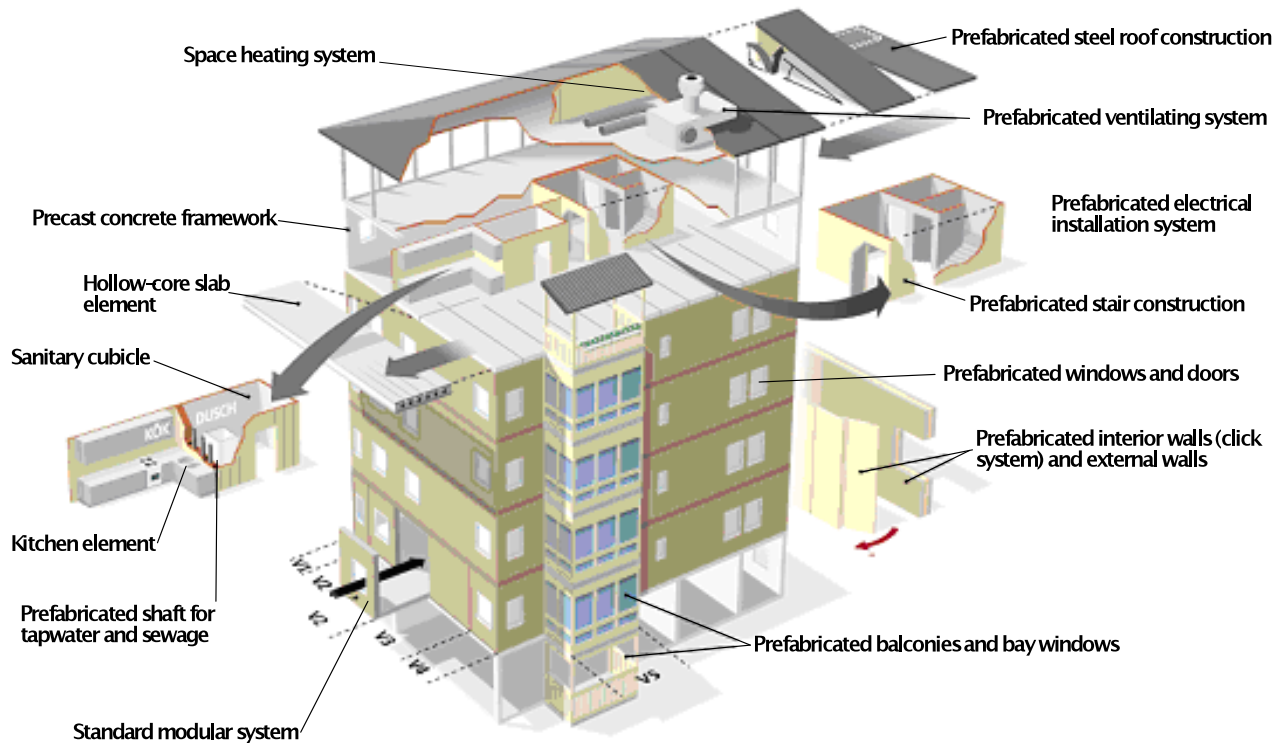

Figure 2: Principles of a multi-dwelling building built under the concept Skanska ModernaHus, product Grönskär (Skanska 2010)

2. METHOD

In order to investigate the development process, an experimental software development of a configuration system module was initiated. The experimental module should provide the service of energy analysis as part of a complete configuration system. The software development was carried out by the first author who's a graduated structural engineer with knowledge and practice in engineering software development.

It was expected that this experimental software development will uncover and validate details of requirements, development activities and the choice of technology.

The experiment is based on the existing practice of ModernaHus, taking its Grönskär product as test bed for the module (Figure 2). Some aspects of the design left open for customization, we call these aspects *open parameters*. The experimental module leaves only a few parameters open to ease the research efforts. An operational configuration system will contain more open parameters to facilitate the customization process in the project delivery phase. Even with limited number of parameters, valuable experiences for the development of a configuration system module will be collected. The selection of a more complete set of open parameters for an operational configuration system – based on business goals and user requirements – will become a standalone activity on its own (Hvam, Mortensen and Riis 2008).

Based on an incoming set of open parameters the module should produce selected energy performance results for the chosen building design. From the development experiment point of view any results is suitable that supports comparing the performance of the available variants through the defined open parameters.

The module should support the activity of salesman and customer discussions: the selection of the desired values for the open parameters. This activity is considered to be the core of the configuration process.

The analysis software used in the experiment is the calculation engine of the VIP-Energy (2010) software, called VIP-Core, product of StruSoft (2010). The VIP-Core engine is a natural choice since it is already used in the analysis of ModernaHus products through VIP-Energy and it is available from the StruSoft which is an active member of the research project. Additionally, the engine provides an XML based interface which could easily be used in various system architecture – the engine already works in Windows and OSX systems and it is utilized both in local and server based environments worldwide (e.g. EcoDesigner 2010, VIPWEB 2010).

The experiment was determined to be carried out in Windows environment and by the use of Microsoft's software development tools and technology. For the sake of simplicity a fully local implementation was preferred in the experiment compared to client-server architecture. The module is executed where the input data is generated with the help of a temporary user interface. However the design of the module should not hinder, it even should support the application of the same functionality in client-server or distributed environments. The future configuration system – where the module is going to be implemented – should support the cooperation of the various participants of the product configuration process who might be situated in various locations.

3. SOFTWARE IMPLEMENTATION

3.1 Input parameters

The open parameters – the actual user input – of the module was selected so that it could represent a hypothetical, simple, but potentially real life situation. The aim was to represent the configuration of product and its application conditions, but to a minimal extent since the focus is on experimenting on the process of development that leads to a configuration module.

The selected open parameters for this experiment are the followings:

- Location: geographic location for climate data.
- Orientation: the angle of the design relative to the geographical true north.
- Lowest horizontal angle of sun in the surroundings: 8 angle values for the eight geographic directions of north, north-east, east, etc.
- Number of floors in the building.

The floor number is a design dependent value, it has a minimum value of 3 and a maximum of 8. The product design is optimized for this range of floor numbers. The location is a name which identifies the climate conditions for the building: thermal, solar, wind and humidity parameters. The conditions defined in *Climate Files*, one file represents one location. We use the built in climate files from the VIP-Energy, energy calculation is available for the locations represented by these files. New climate files can otherwise be created by the VIP-Climate web service which is based on NCEP (2010) Daily Global Analyses data provided by the NOAA/OAR/ESRL PSD, Boulder, Colorado, USA. The horizontal angles are determined by the way the VIP-Core handles sun conditions. The effect of terrain and surrounding building or other obstacles blocking the sun path are considered through these values. It shows the minimum angle of the visible sun relative to the horizon for the eight principal geographical directions.

All other input – fix parameters – of the module necessary for the analysis – geometry, thermal parameters, occupation, etc. – were defined based on the design documents of the Grönskär product. It is not in the scope of this paper to describe the fix parameters in more details. For the purpose of experimenting with configuration module development any parametric design is suitable; our sample in this case happened to be the Grönskär since its design documents were readily available.

3.2 Input interface

In general XML format is selected for the data definition format of the module based on two main reasons:

- It is the format used in the VIP-Core calculation engine
- The format is a well known and widely supported format in computer technology

For the scope of the experiment file based exchange was selected for the sake of simplicity, but it could be changed to other XML compatible exchange mechanism to deliver the same information. Internet or at least intranet communication is a likely situation for the final configuration system. With XML the parsing and the creation of the information could remain the same even if the data transfer medium is changed.

The open parameters of the building are defined in a file denoted *Parameter File*. Two other files define the fixed and the design dependent building information. One file that contains generic analytical input for the calculation except floor number dependent values. This file is called *Building Template File*, it contains values such as thermal conductivity values of structure types, details of installations, usage aspects, etc. Some information, like the location dependent values, are considered to be placeholder in this file and become overwritten during the configuration process. The other building design related file is called *Building Geometry Template File*. This file contains the floor number and orientation dependent parameters. It contains information about the area and orientation of the various building parts for one floor and for the whole building (like geometry of roof, engine house, etc).

Altogether 4 files compose the input of the energy analysis module:

- Parameter File
- Climate File
- Building Template File
- Building Geometry Template File

3.3 Output

The output of the module is the actual output file of the VIP-Core calculation. It contains energy consumption and other results showing the energy performance of the building. For full details please refer to VIP-Energy (2010) documentation. The output contains more results than we need for the experiment but there was no need to process the output further just to reduce the size of the output file.

For presenting result on the user interface the yearly heating requirement for the whole building and for unit occupational area was selected (see Figure 4.) as basic and important properties of the building design. It is not in the focus of this paper to present and evaluate the full set of results for the individual executions; for experimenting with the development process and comparison of design alternatives any input and any of the results is suitable.

3.4 Process flow

The execution units and the process and information flow in the module is shown in the Figure 3. The execution starts and ends in the temporary Excel based *User Interface (UI)*. The core product of the experiment is the *Configuration Module (CONF)* which generates the *Analysis Input File (A.IN)* for the *VIP-Core analysis module (ANA)* from the *Building Template File (BT)*, *Building Geometry Template File (BGT)* and the selected *Climate File (CLIM)* based on the open parameters in the *Parameter File (PRM)*. The *User Interface (UI)* generates one *Parameter File* for each input line of its interface sheet, executes the *Configuration Module (CONF)* and the *VIP-Core Analysis Module (ANA)* sequentially for each *Parameter File (PRM)*, then reads out the selected results from the *Analysis Output file (A.OUT)*, displaying in the corresponding row.

In the final system the process flow will be controlled by the selected system environment while the interface of this module will remain the *Parameter Document* (input interface) and the *Analysis Output Document* (output interface). Note that the term document is used for the future systems input and output since the manifestation of the XML format data might change from the currently selected file based one.

4. RESULTS

4.1 Execution

Execution of the module is very fast. Calculating 50 configurations take less than 20 seconds, including interface operations, which means less than 0.4 sec each. It means we almost can see the effect of design parameter change in real-time. The execution took place in a virtual environment: Windows XP running in a VMware Fusion 3 virtual machine over an OSX Snow Leopard, on a MacBook Pro 2.4 GHz Core 2 Duo computer with 4G of memory, 5400 rpm HD.

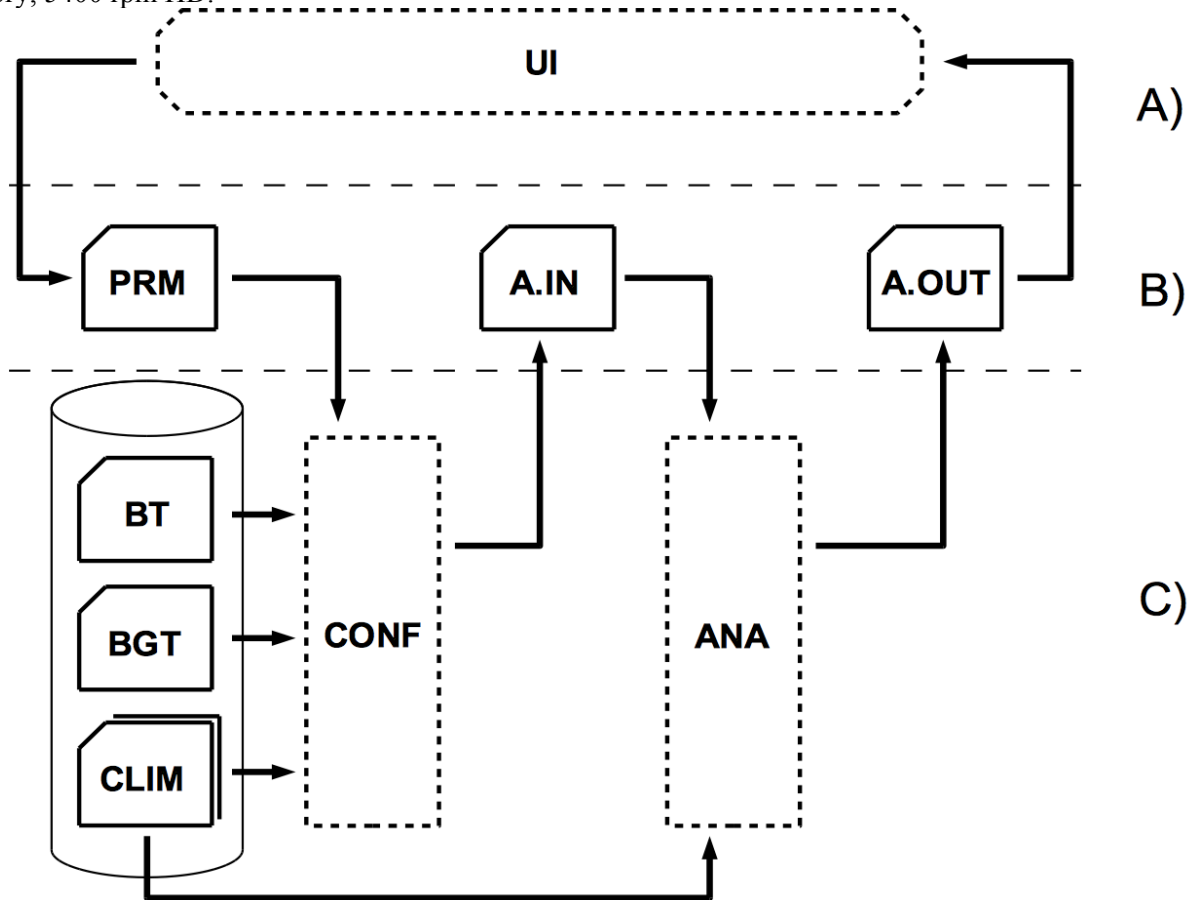

Figure 3: Process and information flow of the module during execution. UI = temporary user interface module (execution starts and ends here); PRM = input parameters; BT = building template; BGT = building geometry template; CLIM = climate data; CONF = configuration module; A.IN = analysis input; ANA = VIP-Core analysis module; A.OUT = analysis output; A) control and user interface parts; B) operational data; C) system specific parts and data

Even with limited number of open parameters the module could be used to investigate several useful things. For example:

- For the same design we could optimize the orientation and select the one that minimizes the heating requirement (see Figure 4).
- Analyze the effect of changes in the surroundings – like new buildings, growing vegetation – through changes in solar conditions.
- Check how the energy requirement changes in case of changing floor number.

With increasing number of open parameters the possibilities for analysis and optimization will also increase.

4.2 Development experiences

The overall time spent on development took about 4 calendar weeks for the first author, including some learning activities of file format, development for Excel, etc. It is difficult to assess the pure software development time requirement for generic operational situation but it is believed that for an experienced and focused developer with the help of carefully prepared specification, the time requirement of software development could be measured in days rather than in weeks. Using both XML and .NET is quite straightforward and intuitive way of development, engineers with moderate software development knowledge shall be able to carry out such tasks without too much difficulty.

	G	H	I	J	K	L	M	N	O	P	Q	R	S	T
2	Location	Orientation	Floors	Horizontal angles								Heating	Heating/m2	
3		[deg]		N	NE	E	SE	S	SW	W	NW		kWh	kWh/m2
4	Stockholm	0	3	5	5	5	5	5	5	5	5		25562.20	26.19
5	Stockholm	15	3	5	5	5	5	5	5	5	5		25426.19	26.05
6	Stockholm	30	3	5	5	5	5	5	5	5	5		25274.64	25.90
7	Stockholm	45	3	5	5	5	5	5	5	5	5		25122.15	25.74
8	Stockholm	60	3	5	5	5	5	5	5	5	5		25314.54	25.94
9	Stockholm	75	3	5	5	5	5	5	5	5	5		25508.90	26.14
10	Stockholm	90	3	5	5	5	5	5	5	5	5		25691.80	26.32
11	Stockholm	105	3	5	5	5	5	5	5	5	5		25840.17	26.48

Figure 4: Analyzing orientation

Though the architecture of the module is nowhere close of being complex one aspect still can be recognized from the flow diagram in Figure 3. We might consider the module together with the Excel based temporary user interface (UI) being a very simple configuration system of its own. Then the middle section of the three dashed line separated sections, the part B), represents the operational data in the system. The user interface of part A) captures and presents the actual instance dependent operational data. The lower section, the part C), represents the system specific permanent data and operational units. The items here are formulated or selected during the development of the system. With other words the part C) – the module itself – together with the part A) compose a small configuration system while the part B) represent the operational data which is generated during the system usage. Like in a more complete configuration system we have operational and fix data and the module contains sub-modules.

During the specification of the data model for the BT and BGT parts we have recognized that the data model of these files and the structuring of information is highly affected by the nature of open parameters in PRM. Although it was not essential to separate generic analytical input data from geometry specific ones (divide template analytical input into BT and BGT parts) it was practical to do so from program code writing and template data management point of view. If the design was floor number independent then this separation had not been made. Since the CONF module's role is to combine the PRM, BT and BGT files into one analytical input file, any changes in the data format in any of these three parts could affect the CONF module too. With other words, the design of PRM data from the operational layer strongly interacts with the data modeling and process design of the system layer.

5. DISCUSSION

An obvious advantage of the module is its quick operation which is mainly the fame of the VIP-Core calculation engine. This impressive speed is necessary in a complete configuration system where the energy performance calculations are only one task amongst the many. The quick operation not only enhances the user experience but more importantly enables better quality and better performance buildings by analyzing more configurations of the building during the same given period of time. Quicker operation also provides more space for client interaction and cross-discipline optimization, for example balancing between the construction costs and long term environmental impact through energy consumption.

The chosen analysis sub-module of VIP-Core not only found to be efficient but easy to work with because of its modular characteristics. It is easy to feed with data, execute and process its results without the use of complex propriety technology and without the handling of big integrated software system. If the calculation was only available through a complex software system then the software development part of the configuration system had been more difficult. Using modular components is beneficial.

Concerning the selection of existing software modules we seen that the characteristics of the module could affect the data modeling and internal communication of the system. In our case the way the VIP-Core is modeling the obstacles of the buildings environment with 8 horizontal angle values has affected the interface of the module. The features of the chosen software modules could affect even the choice of open parameters, consequently the values exposed to the user interface. The choice of software could affect many aspects of the configuration system therefore decisions on system architecture should be preceded or coupled with decisions on the choice of software modules.

The fundamental assertion of Hvam, Mortensen and Riis (2008) about the need of careful product range selection can be captured through this module too. Since considerable amount of information is fixed during the concept development phase any necessary change to the design might require costly and time consuming development tasks (both concept and software development). Dividing the system into modules with limited functionality and dependency could make changes simpler to implement, but activities such as testing, documentation, introduction still represent mandatory and time consuming activities even in case of narrow changes. Incautious selection of product range could have costly consequences on the use of the system. Careful balancing between flexibility and system performance is an essential initial activity before starting the development of the system.

As mentioned in the development experiences section above, the operational data and the system specific data, and consequently the processes, are strongly coupled. These parts together produce the complete information set for the actual construction. Any change in the data model of one triggers necessary change in the others. This also means that if by chance we would combine changed system parts together with unchanged system parts it would result in malfunctioning configuration process. Consequently great care should be taken for ensuring the use of compatible system parts together, especially when the evolution of the configuration system happens in parallel with ongoing configuration activities. For the sake of operational system all necessary and compatible system components should be available simultaneously, at least for all ongoing processes, but in case of need for all the archived building designs too.

A production ready configuration system contains more products and more open parameters than this experiment. Any new or changed products require the re-development of the system modules. These activities should be planned, implemented and tested. Also any improvement or maintenance of the system (bug fixing) requires continuous development work. Consequently the availability of adequate software engineering resources, both staff and infrastructure is a must for similar configuration systems. Those organizations that are planning the implementation and operation of a configuration system will have more software related duties than in the typical purchase and use model used today. With other words over the existing software related purchase, education, operation and update related activities the software development tasks will appear on the list of duties for the organization.

Since the planning and implementation of the system requires both construction engineering and software engineering knowledge the need for inter-disciplinarily concept development team emerges. This need could be

satisfied with combining personals from construction engineering and software engineering disciplines into the same team or by employing fewer but cross-discipline educated personal.

As a summary, we could see that energy analysis automation for industrialized processes pose new tasks and challenges on design teams; however, it is compensated with the increased possibility of finding more energy efficient designs through providing more time for selecting the best available design variant and providing constant quality results quickly. Combining the automation with decision making techniques the results could be even more reliable through increasing the transparency of the procedures (Schade, 2009). Through finding designs with higher energy efficiency, automated solutions could contribute positively to the economy and to the environment.

6. FUTURE WORK

The experimental module of this paper will become the part of a more complete but still experimental configuration system in the near future. The module will likely encounter several changes in the parameters and operation which might allow us to draw future conclusions around the maintenance and improvement of the energy analysis module. We might also gain further experiences concerning system integration of the various modules. We will likely learn more about optimal ways of information storage, improvements managements in complex systems and organizations, introduction of the system into existing construction organizations, and hopefully we might be able to measure in long term the benefits and problems appear during the use of a building configuration system.

ACKNOWLEDGMENTS

We would like to acknowledge the help provided by Mats-Ola Rasmusson, Strusoft in supporting the VIP-Core engine, and the resources and help the Strusoft management was dedicating to the research. We'd also like to thank for the detailed information provided about the ModernaHus concept for Carl Jonsson and Björn Berggren in the Skanska. The work has been supported by the Swedish Research Council Formas (SE+358961522072) for which we are very thankful.

REFERENCES

- Andersson R., Apleberger L. and Molnár M. (2009). Erfarenheter och effekter av industriellt byggande i Sverige, Malmö: Sveriges byggindustrier (Technical report 0905) (In Swedish)
- Bazjanac (2009). Implementation of semi-automated energy performance simulation: Building geometry. *CIBW078 26th Conference proceedings*. Istanbul, TK 595-602, CRC Press. 595-602
- Egan Report (1998). Rethinking Construction. HMSO, London
- EcoDesigner (2010). <http://www.graphisoft.com/products/ecodesigner>. Accessed: 2010-09-
- Kadefors, A. (1995). Institutions in building projects: implications for flexibility and change. *Scandinavian Journal of Management*, 11(4) : 395-408
- Kunz, J. and Fischer, M. (2009). Virtual Design and Construction: Themes, Case Studies and Implementation. *CIFE Working Paper #097*. Version 10, Stanford University, October 2009
- Lessing, J. (2006). Industrialised House-Building. *Licentiate thesis, Department of Construction sciences, Lund institute of technology, Sweden*
- Hvam, L., Mortensen, N. H., Riis, J. (2008). Product Customization. *Springer-Verlag Berlin Heidelberg*. ISBN 978-3-540-71448-4
- Häkkinen et al (2007). ICT for whole life optimization of residential buildings. VTT-report, 2007. <http://www.vtt.fi/inf/pdf/tiedotteet/2007/T2401.pdf> (2010)
- NCEP (2010). Daily Global Analyses data provided by the NOAA/OAR/ESRL PSD, Boulder, Colorado, USA. <http://www.esrl.noaa.gov/psd/>
- Patni (2010). <http://www.patni.com>. Accessed: 2010-09-20

- Schade, J., Olofsson T. (2009). A model-based design approach with the focus on energy. *Proceedings of 5th Nordic Conference on Construction Economics and Organisation*. University of Reykjavik. 167-183.
- Skanska (2010). <http://www.skanska.com>. Accessed: 2010-09-20
- SOU 2002:115 (2002). Skärpning gubbar! Om konkurrensen, kvaliteten, kostnaderna och kompetensen i byggsektorn (In Swedish). <http://www.regeringen.se/sb/d/108/a/1649>. Accessed: 2010-09-20
- SOU 2009:6, (2009). Sega gubbar? En uppföljning av Bygghälsöns betänkande ”Skärpning gubbar! (In Swedish). <http://www.statskontoret.se/upload/Publikationer/2009/200906.pdf>. Accessed: 2010-09-20
- Strusoft AB (2010). Structural Engineering Software in Europe AB. <http://www.strusoft.com>.
- Teicholz, P., Goodrum, P. M., Haas, C. T. (2001). Discussion of U.S. Construction Labor Productivity Trends, 1970-1998, *Journal of Construction Engineering and Management*. 127 : 427-428.
- VIP-Energy (2010). <http://vip.strusoft.com>. Accessed: 2010-09-20
- VIPWEB (2010). <http://vip.strusoft.com>. Accessed: 2010-09-20
- Winch, G. M. (2003). Models of manufacturing and the construction process: the genesis of re-engineering construction. *Building research and information*. 31(2) : 107-118.